

**Military Technical College
Kobry El-Kobbah,
Cairo, Egypt**



**11th International Conference
on Electrical Engineering
ICEENG 2018**

Development of a Digital Model of the Egyptian Power Grid for Steady-State and Transient Studies

By

Omar H. Abdalla*, A.M. Abdel Ghany*, and Hady H. Fayek**

ABSTRACT

This paper presents the development of a digital model to simulate the Egyptian power grid at 500 kV and 220 kV levels. A professionally available DIgSILENT power system computation package is used. A brief description of the system is given, which includes generating units, transformers, transmission lines and loads. The system includes different types of power plants such as thermal, hydro, and wind. The automatic voltage regulator and speed governor of each unit are simulated in the model. The model is used to perform power system studies such as load flows, short circuit, contingency and stability for the purposes of performance evaluation and insuring compliance with the technical requirements of the Grid Code. The Performance Code of the Egyptian Grid Code is briefly described and used to evaluate the system performance at different operating scenarios, including steady state and transient analyses. Sample of the simulation results are presented to show the capabilities of the model in various system studies.

KEY WORDS

Egyptian Power Grid, Power Flow, Short-Circuit, Contingency, Large-Disturbance Stability, Small-Disturbance Stability, Grid Code.

* Dept. of Electrical Power and Machines Engineering, Helwan University, Cairo, Egypt.

** Dept. of Electro-Mechanics Engineering, Heliopolis University, Cairo, Egypt.

I. INTRODUCTION

Electricity utilities over the world perform power system studies by using digital models to simulate electric grids. The models are used for long-term and short-term planning studies including steady-state and dynamic analyses. These models are based on computer packages with versatile facilities to represent large scale power systems, including generators, turbines, exciters, transformers, transmission lines, loads and various control devices [1]–[8]. These commercially available software packages provide a convenient platform for system studies. A general review of power system modelling platforms and capabilities is described in [9]. Various power system analysis software tools are reviewed and compared in [10]. The software tools are used for performing test cases and scenarios in an offline environment so that electric power grids can be professionally planned, optimized and operated.

DIGSILENT *Power Factory* software provides highly specialized services in the field of electrical power systems for energy transmission, distribution, generation, industrial plants, renewable energy and smart grid [1]. The name DIGSILENT stands for "Digital Simulation and Electrical Network calculation program". It provides an integrated power system analysis software package covering the full range of standard and highly complicated applications. This professional software is widely used in power system analysis by electricity utilities and research academia worldwide [11]-[17]. Application to Nordic32 test system (with 400 kV, 220 kV and 130 kV) is described in [11]. A test system model for stability studies of UK power grid is presented in [12]. The studies concerned with future UK system with different types of generators including high penetration of wind energy. Modelling and steady state analysis of the 400 kV and 220kV Indian North Eastern Regional Grid are explored in [13], using PSS®E and DIGSILENT. Dynamic analysis of Southern Africa Power Pool (SAPP) network is described in [14]. The SAPP network consists of twelve countries represented by the electric utilities in addition to two independent power producer and independent transmission company. The SAPP model is mainly at 400 kV and 330 kV level. Various applications of modeling and studies of power systems are available in [15]-[16]. Development of a digital model of Oman power grid using is described in [17].

This paper presents the development of a digital computer model which represents the 500/220 kV Egyptian grid, using DIGSILENT software. The model is used for the purposes of system steady-state and transient studies. The grid was simulated based on the 2016 available real operating conditions in terms of maximum load, generator static and dynamic data, transmission lines data and transformers data. To achieve a reliable, secure and high-quality operation for the power system, a grid code should be followed. The grid code includes the limits and constraints of power system elements operation at different conditions. In this paper the Performance Code of the Egyptian Grid Code [18] is briefly described and used to evaluate the system performance at different operating scenarios.

The software package is briefly described in Section II. The Egyptian power system is described in Section III. Section IV describes system modeling and section V provides a brief discussion on the Performance Code of the Egyptian Grid Code. Section VI presents sample of results, and finally Section VII summarizes the main conclusions.

II. DIgSILENT SOFTWARE

In order to simulate a real power grid and perform static and dynamic studies, software with high capabilities should be used. In this paper, the professional software package DIgSILENT PowerFactory [1] is used for modelling and system studies of the Egyptian power grid. It is a computer aided engineering tool used for power system studies of utility, industrial, and commercial electrical systems. It has been developed as an advanced integrated and interactive software package to facilitate necessary studies leading to satisfy the main objectives of power system planning and operation optimization. The following main integration characteristics make the DIgSILENT a unique power system analysis tool:

- i. Vertical integration
- ii. Functional integration
- iii. Database integration

The concept of vertical integration allows sharing of models of system components among all analysis functions which include: load flow analysis, optimal power flow, short-circuit analysis, contingency analysis, stability, EMT simulations, eigenvalue calculation, model parameter identification, reliability assessment, harmonics analysis, optimization of distribution networks, protection system, network reduction, and state estimation. The database integration means all data required for defining case studies, operational scenarios, one-line diagram, other graphics, outputs results, running conditions, calculation options, and user-defined models, are common in the DIgSILENT representation of the grid. The simulation of the grid is done by drawing the single line diagram of the grid and then entering the data of each component or by selecting its type using the program built in library. A user library can be established for the study system containing selected and new defined models.

Nowadays smart grids with increasing renewables penetration levels became a global trend, this software helps in this process by including models of all renewable sources and enabling the entry of the source characteristics which reflect the facts of the variability and uncertainty of renewable source. DIgSILENT also provides DGS files interface which enables large data exchange in online mode or offline mode with other software applications such as GIS and SCADA. Its typical applications include optional export of grid models, graphic models, or calculation results from DIgSILENT into external data source and import of complete grid models into it [19].

III. EGYPTIAN POWER SYSTEM DESCRIPTION

The simulated 500/220 kV Egyptian grid consists of: 23 single-circuit structure 500 kV transmission lines, 172 double-circuit 220 kV transmission lines, 23 single-circuit 220 kV transmission line, 1 four-circuit 220 kV transmission, 38(500/220 kV) autotransformers, 213 two-windings unit transformers in addition to loads and static reactive power compensators (reactors and capacitors). Fig.1 shows a geo-schematic diagram of the Egyptian power grid [20] after being updated to include: Nubaria and K.Zyat busbars, (Nubaria-Sidikrir, Nubaria-Cairo500, K.Zyat-A.Zaabal, AbuKir-K.Zyat, K.Zyat-Bassous) 500 kV lines and (RasGharib-Gabalzeet, RasGharib-Zaafarana, Gabalzeet-Hurghada,

AboRadees-Altoor, Altoor-Sharm, K.Zyat-Tanta) 220 kV lines.

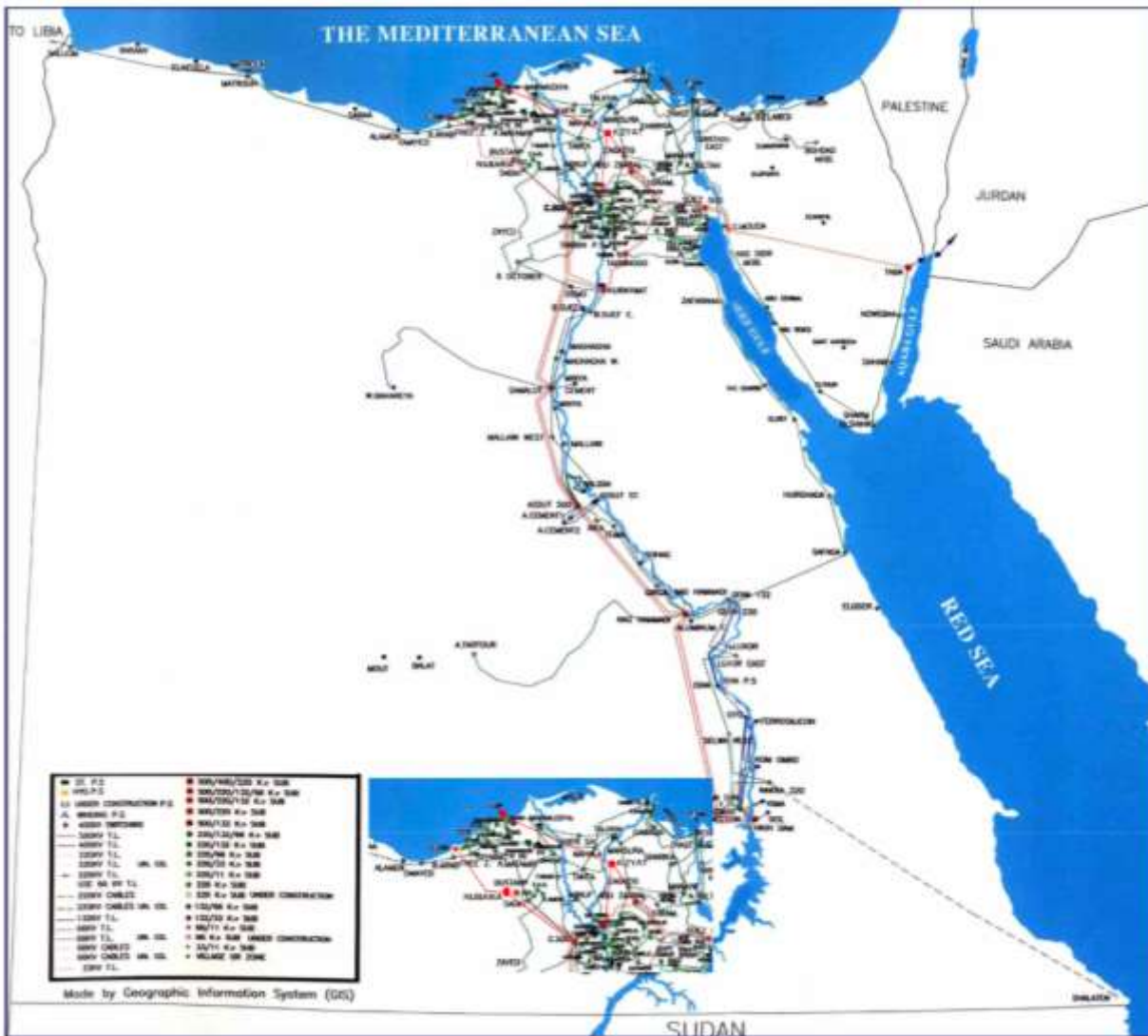

Fig. 1.The Egyptian grid [20].

Currently, the Egyptian grid is connected to Libya power grid (at 220 kV level) and to Jordan power grid (at 500/400 kV level). In near future it will be connected to Saudi Arabia grid through a DC link to exchange 3000 MW. The Egyptian transmission grid is fed from the power stations listed in Table I, based on 2016 data. The three large power plants at New Administration Capital, Beni Sweif and Burolos are still under construction. These new power plants are not included here, but can be added to the model after fully commissioned. The loads were simulated based on the 2016 peak load which is 30.8 GW as shown in Fig. 2 [21].

IV. SYSTEM MODELING

A. Synchronous Generators

The simulated Egyptian grid includes 213 generating units in 42 power stations with ratings varies from 5.8 MW in Sharm Sheikh for the smallest unit to 650 MW in Ain

Sokhna and Abu Kir New for the largest unit. The generator is modeled by a 7th order dynamical model [22], [23].

Table 1: Power Stations in the Egyptian Power Grid – 2016 Data.
(GT: Gas Turbine, ST: Steam Turbine)

Station	Generation Capacity and Type
Six October	8 x 150 MW GT
Abu Kir	4 x 150 MW ST + 1 x 311 MW ST
Abu Kir new	2 x 650 MW ST
Alshbab	3 x 33.3 MW GT + 8 x 125 MW GT
Alwaleedia	2 x 321 MW ST
Arish	2 x 33 MW ST
Aswan Dam	7 x 40 MW Hydro + 4 x 67.5 MW Hydro
High Dam	12 x 175 MW Hydro
Cairo west	2 x 330 MW ST+ 2 x 350 MW ST
North Giza	3 x 250 MW ST+ 6 x 250 MW GT
Mahmoudia	8 x 25 MW GT+ 2 x 58.67 MW ST + 2 x 168 GT
South	1 x 110 MW GT+ 1 x 55 MW ST+ 3 x 110 MW GT
Sharm Sheikh	1 x 23.7 MW GT + 4 x 24. 27 MW GT + 4 x 5.8 MW GT
ShoubraKhema	4 x 315 MW ST
Suez boot	2 x 341.25 MW ST
KafrDwar	4 x 110 MW ST
Gabalzeet	Total (200 MW Wind
Zaafarana	Total (547 MW Wind
Tebbeen	2 x 350 MW ST
Sidikrir	2 x 250 MW GT + 1 x 250 MW ST + 2 x 320 MW ST
Nubaria 1,2	2 x 250 MW ST+ 4 x 250 MW GT
Nubaria 3	2 x 250 GT +1 x 250 ST
Alatf	2 x 250 MW GT + 1 x 250 MW ST
Banha	2 x 250 MW GT + 1 x 250 MW ST
Attaa	2 x 150 MW ST + 2 x 300 MW ST + 2 x 156 GT+ 2 x 164 GT
Matrouh	2 x 30 MW ST
Domiat	6 x 132 MW GT + 3 x 136 MW ST + 4 x 125 MW GT
West Domiat	8 x 125 MW GT
Talkha	2 x 250 MW GT + 1 x 250 MW ST + 2 x 210 MW ST+ 8 x 24.72 MW GT + 2 x 45.93 MW ST
Port Said Boot	2 x 341.25 MW ST
Wadi Hoof	3 x 33.3 GT
Kurymat	2 x 627 MW ST
Kurymat 2,3	4 x 250 MW GT + 2 x 250 MW ST
Damnhour	1 x 300 MW ST
Damnhour GIS	4 x 25 MW GT + 1 x 58 MW ST
Sidikrir boot	2 x 341.25 MW ST
Abo Sultan	4 x 150 MW ST
Ain Moussa	2 x 320 MW ST
Ain Sokhna	2 x 650 MW ST
Hurghada	6 x 23.86 GT
North Gen.	4 x 250 GT + 2 x 250 ST
Assuit West	4 x 125 GT

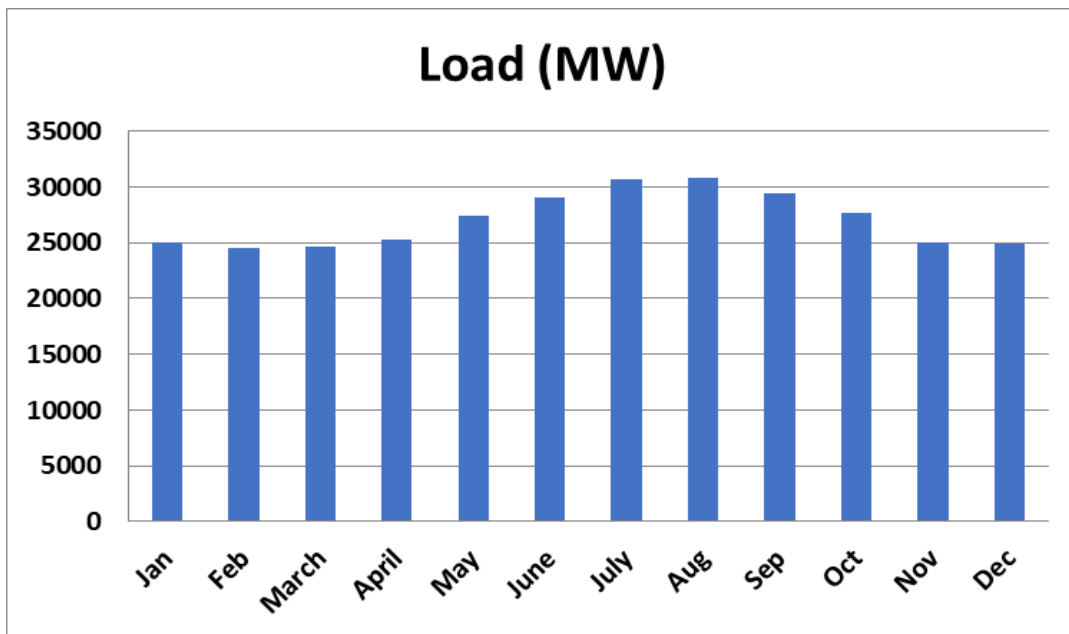

Fig. 2. Egyptian Monthly Demand in 2016 [21].

The DigSILENT provides highly accurate models to represent the generators which can be used for the whole range of different analyses starting from load flow calculations to very complex transient simulation. The program represents the magnetic saturation and considers its effects in the simulation.

B. Prime Mover and Governor Systems

The generating units of the Egyptian grid are driven by gas turbines, steam turbines, hydro turbines, combined cycle (gas + steam) in addition to wind turbines. The program library contains various types of turbine standard models including IEEE representations [24]. The user can select the model which represents with the turbine type. Alternatively, if a particular model is available, it can be simulated in the model. Fig. 3 shows the selected models of the turbines and speed governors. The GAST model is used to represent all gas turbine and speed-governor systems, in the Egyptian grid, either open cycle or combined cycle types. The TGOV1 model is used to represent steam turbine prime mover systems. These include conventional separate steam turbines or that part in a combined cycle configuration. In the combined cycle power plant, the governor valve of the steam part is made insensitive to frequency variations, since the frequency response is usually achieved through the speed governor of the gas turbine part. While the HYGOV represents the governor of hydraulic power station as illustrated in Fig. 4.

C. Automatic Voltage Regulators (AVRs)

Each type of the generators has its own automatic voltage regulator to keep the generator terminal voltage at a certain set-point [25]. The DigSILENT library includes most of these types. In the Egyptian grid the most used types are IEEE EXST1 model, IEEE SEXS model and IEEE EXAC1 model. Fig. 5 shows the block diagram of the IEEE EXST1AVR model.

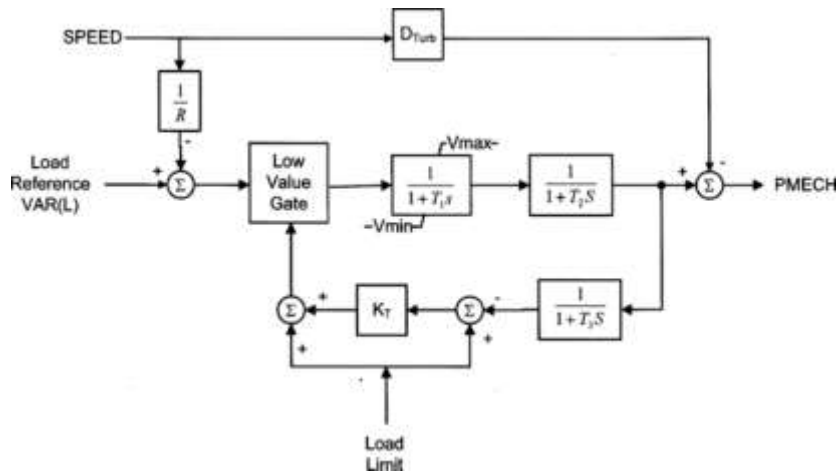

Fig. 3.GASTmodel.

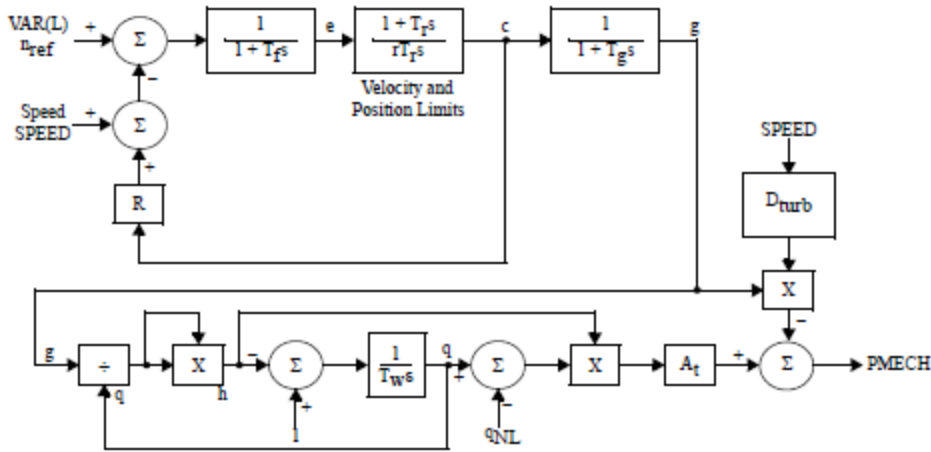

Fig. 4.HYG0Vmodel.

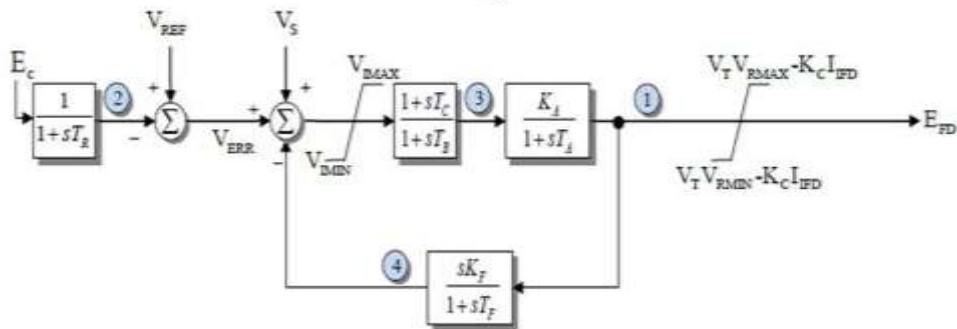

Fig. 5.EXST1model.

D. Transformers

This model includes various types of transformers including 500/220 kV autotransformer, and unit transformers. The transformer type is chosen with a typical number of steps as illustrated in the grid given data. The unit transformers are designed with a MVA rating equivalent to that of the unit generator with tap changing step 1.25%. The ratings of the

500/220 kV transformers are 500MVA while the unit transformers ratings vary between 24 MVA to 500 MVA.

E. Transmission Lines

The model includes transmission lines with different conductor types, different ratings and different voltage levels mainly (500 kV level and 220 kV level). Few lines are 132 kV, but not included here. The transmission line is drawn first in the single line diagram and then its data should be assigned, the type data includes ampere rating, voltage level, positive sequence resistance and reactance, zero sequence resistance and reactance in addition to positive sequence admittance and zero sequence admittance. The lines are all represented in the form of π equivalent circuits. The program asks for the length of the line and the number of circuit to be included in all calculations after inserting the type data. A few cables are included in the transmission lines of the grid with same procedure of input data as the overhead transmission lines.

F. Reactors and Capacitors

There are some shunt reactors and capacitors connected to certain busbars or transmission lines in the Egyptian power grid and are represented in the model. These capacitors and reactors main target is to keep voltage at certain limits in case of increasing or decreasing of the load reactive power. The rating of the reactors varies from 25 to 165 MVAR while capacitors vary from 3.6 to 200 MVAR.

G. Loads

The loads can be represented on the power system as constant active and reactive power or as voltage dependent load or as a dynamic load. The induction motors in the power system represent the most consumed load among all other loads in the power system. The way of load representation differs based on the phenomena of study. In this paper the load is represented as constant active power and power factor.

V. PERFORMANCE CODE

The Egyptian Transmission System Code (ETSC), known as “Grid Code” [12], sets out the relationship between the Transmission System Operator (TOS) and users of the grid which includes: Generation Companies (GENCOs), Distribution Companies (DISCOs) and bulk customers directly connected to the transmission grid. The objective is to ensure safety, efficiency and security of the transmission grid while ensuring that all users are treated equally and fairly. The Grid Code consists of a number of codes. Section 5 of the Grid Code is called the “Performance Code”. It concerns with the quality of electric power and the operation of the transmission system in a safe and efficient manner with a high degree of reliability and specifies safety standards for the protection of personnel in the work environment.

In system studies described here, the following extracts from the Performance Code should be considered:

A. Operational and Planning Criteria

“The 500 kV and 400 kV transmission systems shall be planned and operated so that no single contingency, at these voltages levels, results in unacceptable frequency, voltage or large scale demand disconnection; this is known as (N-1) criterion. Also, the 220 kV, 132 kV and 66 kV transmission systems shall be planned and operated so that any two contingencies, at theses voltage levels, results in unacceptable frequency, voltage or large scale demand disconnection; i.e. (N-2) criterion.”

B. Voltage Limits

“Under normal operating conditions, the voltage at all connection points should be limited between 95% and 105% of its nominal value. The voltage may fall to a value between 90% and 95%, or rise to between 105% and 110% for a period not exceeding 1 minute. During a fault, voltages may fall transiently to zero, or may rise to 140%, for a period not exceeds 1 second.”

C. Frequency Limits

“The nominal fundamental frequency in the Egyptian grid shall be 50 Hz. The control of the system frequency shall be the responsibility of the TSO; which is the Egyptian Electricity Transmission Company. The TSO shall maintain the system frequency within 49.95 Hz and 50.05 Hz during normal operating conditions.”

D. Short-circuit Level

“Short circuit duty for all circuit breakers in the grid must be consistent with the Table 2.”

Table 2. Short-circuit duties.

Nominal Voltage	Design Fault Level	Withstand Fault Duration
500 kV	40 kA	1 s
220 kV	40/50 kA	1 s
132 kV	31.5 kA	1 s
66 kV	31.5kA	3 s

VI. SYSTEM STUDIES

A. Power Flow Calculations

Tables 3 and 4 show samples of the power flow calculation results for the simulated Egyptian power grid. Table 3 includes the voltage in per unit and voltage angle while Table 4 includes the loading in percentage of the lines. The results show that the system is working in an acceptable operating condition where all the generators, transformers, busbars and lines are within the normal ranges as per the requirements of the Egyptian Performance Grid Code as illustrated in the previous section. Cairo500-North Giza transmission line needs attention for not exceeding load.

B. Short-Circuit Calculations

The DigSILENT includes functions to calculate the single phase and three phase short circuit analysis. The complete method is used for calculating the short-circuit current. Table 5 includes sample of the results of single and three phase maximum short circuit currents at some 220 kV busbars. The short circuit current at some busbars (Mahalla, Domiat, New Domiat, October and others) is near the maximum limit mentioned in the previous section. It is recommended to replace the CB at these busbars to 50 kA fault rating if they are still 40 kA. The CB fault rating at Cairo 220 is 63 kA. The calculated short circuit currents at all 500 kV busbars are within the corresponding fault ratings. Other methods for fault current limitations are discussed in [26].

Table 3. Sample of bus voltages of power flow results.

Bus Name	Nominal Voltage (kV)	Calculated Voltage (PU)
AbuZaabal 500	500	0.952
Abukir 500	500	0.963
Ain Mousa 500	500	0.968
Ain Sokhna 500	500	0.956
Bassous 500	500	0.950
Benisuef	220	0.972
Cairo 220	220	0.993
Cairo 500	500	0.962
Cairowest 220	220	0.962
Cairowest 500	500	0.968
KfrDwar	220	1.000
Kurimat500	500	0.991
Trust	220	0.964
TwleedShmal	220	0.974
WadiHoof	220	0.990
Zaafarana 1	220	1.000
Zaafarana 2	220	0.999
Zagazig	220	0.973
Gerga	220	0.950
October	220	0.995
Seyoof	220	0.980
West Domiat	220	1.000

Table 4. Sample of transmission lines loading of power flow results.

Line Name	Voltage Level (kV)	Loading (%)
Abukir500-KafrZyiat	500	47.70
AbuZaabal-Suez	500	13.60
Ain Moussa-Taba	500	18.10
Ain Sokhna-AbuZaabal	500	20.30
Assuit-NH	500	22.86
Assuit-Samalut	500	41.78

Cairo500-North Giza	500	80.30
Zaafarana1- Zaafarana 2	220	26.73
Ain Sera-Basaten	220	17.25
Samoha-Abees	220	36.52
Alektsadia-Suez Boot	220	35.65

Table 5. Sample of short-circuit results.

Bus Name	Three Phase $I_{k''}$ (KA)	Single Phase $I_{k''}$ (KA)
Cairo 220	58.083	60.174
AbuKir 220	28.440	31.724
Mahalla 220	39.402	39.105
Domiat 220	37.713	39.067
New Domiat 220	37.200	39.415
October 220	36.356	38.360
Kysina 220	25.457	21.730
Alwaleedia 220	25.137	21.515
TawleedAlshmal 220	24.964	21.047
Haram 220	24.790	20.914
Airport 220	24.732	20.331
Moatmadia 220	24.395	20.218
Assuit 220	24.365	20.157
South Assuit 220	24.308	20.152
Giza 220	24.250	20.115
Alatf 220	24.032	20.112
Ain Moussa 220	25.688	22.092

C. Contingency Analysis

The DlgSILENT includes the contingency analysis. It enables the user to choose whether to select a certain contingency and study the whole system performance or the program can assume all the possible contingencies and determine the marked result of each one. Analyses are performed to rate the contingencies in terms of the risk that occurred due to the contingency. Table 6 shows the contingencies that lead to under voltage out of acceptable limit which is 10% below the rated value during contingency state. The contingency analysis was performed on the developed model to test (N-2) security for the 220 kV transmission lines and (N-1) security for the 500 kV lines based on the Egyptian Grid Code requirements.

Table 6. Sample of contingency analysis results.

Contingency Name	Affected Busbar	Contingency Voltage	Base Voltage
Cairo 500-North Giza 500 line outage	Magagaa 220	0.744p.u.	0.968p.u.
Refa-South Assuit line outage	Refa 220	0.808 p.u.	0.985 p.u.

A proposed solution to overcome these issues is to install a new circuit to each of the Refa-South Assuit link and Cairo 500-North Giza 500 link, but this would need high costs and may not be practically feasible, particularly in Cairo region. An alternative solution is to install a capacitor of 50 MVar at Refa 220 busbar or and a 375 MVar capacitor at Magagabusbar. In this case the voltage at these busbars will be within the acceptable range.

D. Small-Disturbance Analysis

Small-disturbance stability analysis of the Egyptian power system has been studied by calculating the system eigenvalues. Figure 6 shows the locations of critical eigenvalues in the s-domain. All have negative real parts, thus indicating system stability. The damping ratios of all modes are within the requirements of the Grid Code, although the system model does not include representation of power system stabilizers.

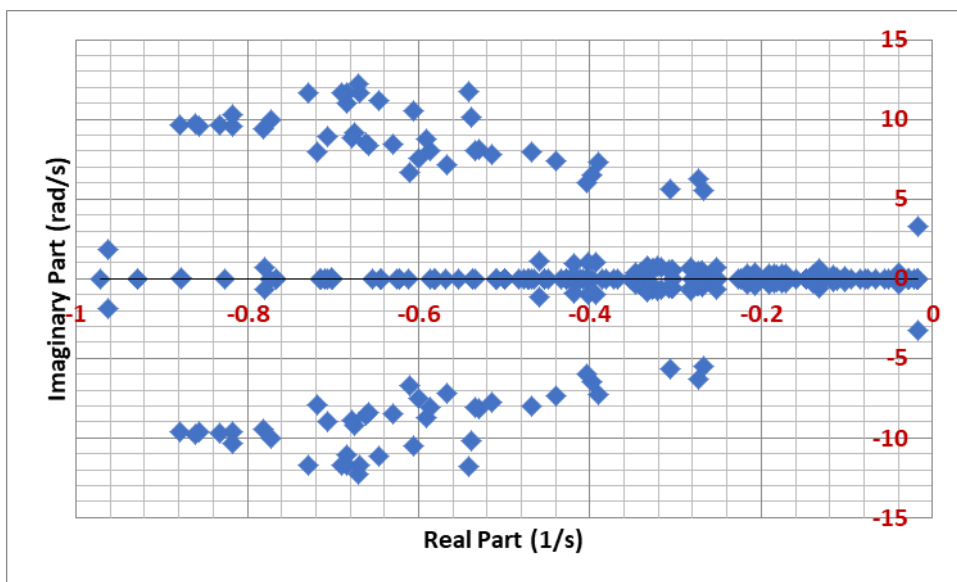

Fig. 6. Critical eigenvalues.

E. Large-Disturbance Stability

Using the developed model, various transient studies can be simulated such as line outage, generator tripping, short circuit, changing load, etc. The program enables the user to record the response of any variable of any component of the system pre-event, during event and also post event. Figures 7, 8 and 9 show the system responses to a three phase short circuit test occurred at North Giza busbar. Frequency, voltage and rotor angle responses are shown. The system is stable with acceptable damping.

VII. CONCLUSION

The paper has presented the development of a digital model for simulating the Egyptian power grid based on a commercially software DlgSILENT power system simulation package. The model has been successfully used in the assessment of power system performance and compliance with the grid code. Simulation results have been presented to show the model capabilities in implementing various system studies. These include both steady state (load-flow & short-circuit, contingency) and transient stability analyses (three-phase fault), in addition to small-disturbance stability study based on eigenvalue analysis. Some problems have been identified such as higher short-circuit levels at some busbars. Proposed solutions to these problems have been discussed. The model can be used in further steady-state and transient studies.

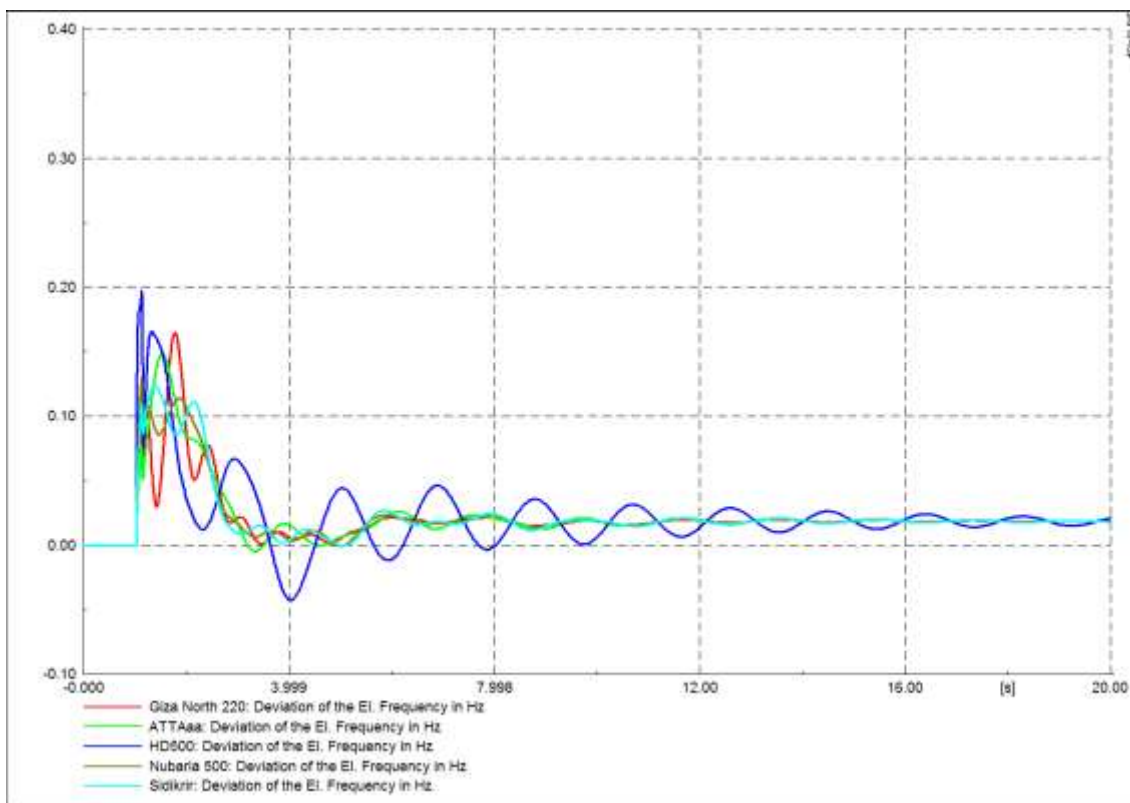

Fig. 6. Deviation of the electrical frequency responses to a threephase short circuit at North Giza busbar.

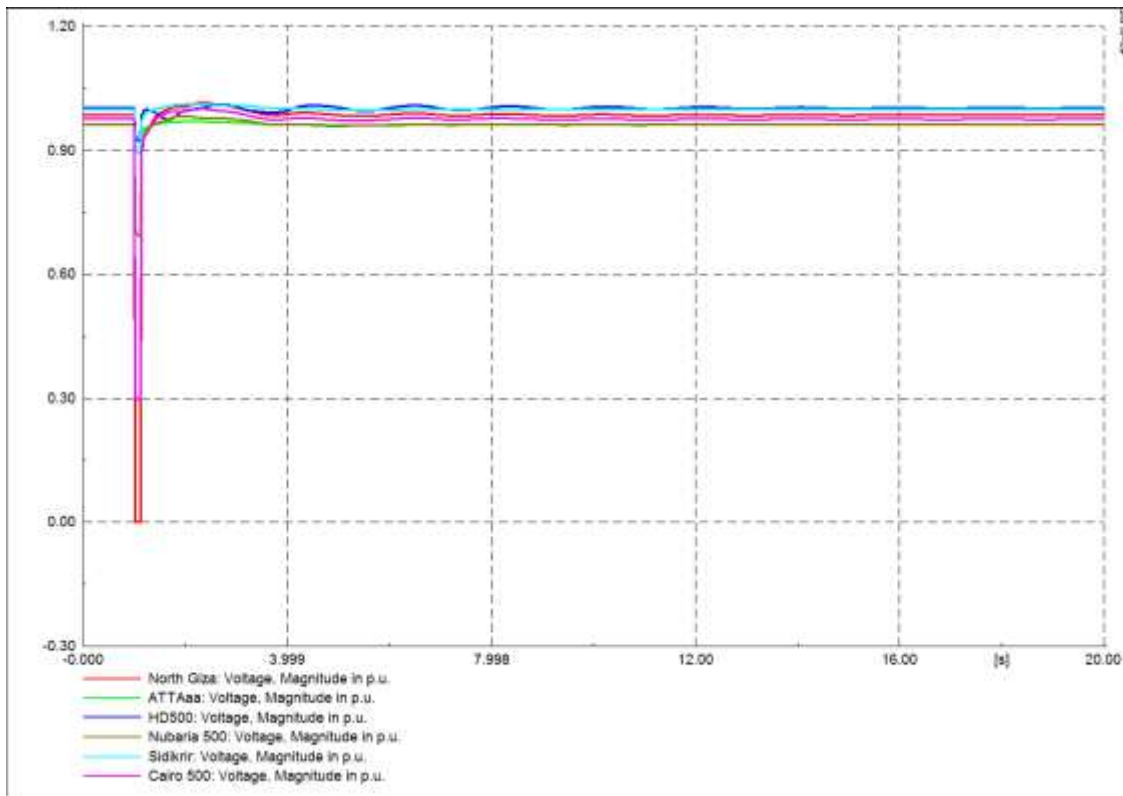

Fig. 7. Voltage responses to a three phase short circuit at North Giza busbar.

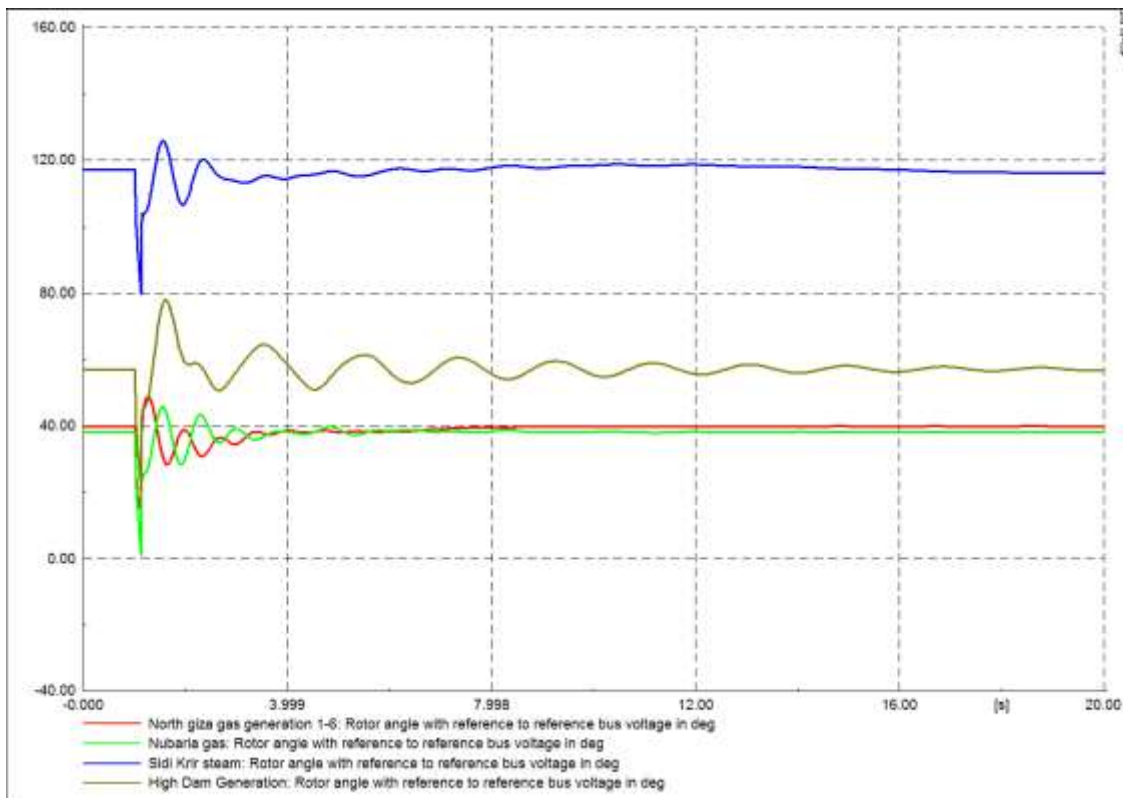

Fig. 8. Rotor angle responses to a three phase short circuit at North Giza busbar.

REFERENCES

- [1] PowerFactoryDlgSILENT GmbH, <http://www.digsilent.de>
- [2] Power System Simulator for Engineers, PSS®E, SIEMENS, <http://www.energy-portal.siemens.com>
- [3] Power Systems Computer Aided Design software, PSCAD, <http://www.pscad.com>
- [4] ETAP Operation Technology, <http://www.etap.com>
- [5] ESA, Inc. - Easy Power, <http://www.EasyPower.com>
- [6] Power World Software, <http://www.powerworld.com>
- [7] Power Engineering Analysis Software, <http://www.cyme.com>
- [8] Power System Planning Software "NEPLAN", <http://www.neplan.com>
- [9] Stephanie Hay, Anna Ferguson, "A Review of Power System Modelling Platforms and Capabilities", Paper 3 of 15, Part 3: IET Special Interest Publication for the Council for Science and Technology on "Modelling Requirements of the GB Power System Resilience during the transition to Low Carbon Energy", pp. 1-13, March,(2015).
- [10] L. Bam and W. Jewell, "Review: Power System Analysis Software Tools", IEEE Power Engineering Society General Meeting, Vol. 1, pp. 139-144, June,(2005).
- [11] L. D. P. Ospina, A. F. Correa and G. Lammert, "Implementation and Validation of the Nordic Test System in DlgSILENTPowerFactory", 2017 IEEE Manchester PowerTech, Manchester, UK, pp. 1-6, (2017).
- [12] L. P. Kunjumammed, B. C. Pal and N. F. Thornhill, "A Test System Model for Stability Studies of UK Power Grid", 2013 IEEE Grenoble Conference, Grenoble, France, pp. 1-6, 16-20 June, (2013).
- [13] K. Gogoi, D. Mishra, N. Debnath, S. Chatterjee and B. Datta, "Modelling and Study of Steady State Analysis and Fault Parameters in 400 kV and 220kV Buses of Indian North Eastern Regional Grid", 2015 International Conference on Energy, Power and Environment: Towards Sustainable Growth (ICEPE), Shillong, India, pp. 1-5, (2015).
- [14] S. Mludi and I. E. Davidson, "Dynamic Analysis of Southern Africa Power Pool (SAPP) Network", 2017 IEEE PES PowerAfrica, Accra, pp. 109-114, (2017).
- [15] A. A. Hajnoroozi, F. Aminifar and H. Ayoubzadeh, "Generating Unit Model Validation and Calibration Through Synchrophasor Measurements", IEEE Transactions on Smart Grid, Vol. 6, no. 1, pp. 441-449, Jan. (2015).
- [16] X. Liu, J. M. Kennedy, D. M. Lavery, D. J. Morrow and S. McLoone, "Wide-Area Phase-Angle Measurements for Islanding Detection—An Adaptive Nonlinear Approach", IEEE Transactions on Power Delivery, Vol. 31, no. 4, pp. 1901-1911, Aug. (2016).
- [17] O. H. Abdalla, Hilal Al-Hadi, and Hisham Al-Riyami, "Development of a Digital Model for Oman Electrical Transmission Main Grid", Proc. of the 2009 International Conference on Advances in Computational Tools for Engineering Applications, Notre Dame University, Louaize, Lebanon pp. 451-456, 15-18 July,(2009). [IEEE Xplore](http://ieeexplore.ieee.org)
- [18] EETC, "Transmission Grid Code", Egyptian Electricity Transmission Company, http://www.eetc.net.eg/grid_code.html
- [19] Jiutong Lin, Dongying Zhang, Jianyang Huang and Dwei Liu, "Research and Development of Grid Model Online in E Imported to DlgSILENT", Proc. of the International Conference on Advances in Mechanical Engineering and Industrial Informatics,(AMEII 2015), Zhengzhou, Henan, China, 11-12 April,(2015).
- [20] Global Energy Network Institute, <https://www.geni.org/>
- [21] The Electricity Regulatory and Customer Protection Agency, <http://egyptera.org/ar/>

- [22] P. Kundur, "Power System Stability and Control", McGraw-Hill, Inc., (1994).
- [23] P. M. Anderson and A. A. Fouad, "Power System Control and Stability", Second Edition, IEEE Press, Wiley, (2003).
- [24] IEEE Task Force on Turbine-Governor Modeling: "Dynamic Models for Turbine-Governors in Power System Studies", Technical Report PES-TR1, pp. 1-117, Jan., (2013).
- [25] IEEE Committee Report, "Excitation System Models for Power System Stability Studies", IEEE Trans. Power Apparatus and Systems, Vol. PAS-100, pp. 494-509, Feb. (1981).
- [26] O. H. Abdalla, H. Al-Hadi, and H. Al-Riyami: "Application of Fault Current Limitation Techniques in a Transmission System", Proc. of the 45th International Universities Power Engineering Conference, Cardiff University, UK, 31st August – 3rd September, 2010. [IEEE Xplore](#)

